

SWF Contract

GRABER® TRADITIONS™
WOOD BLINDS AND
FAUX WOOD BLINDS



WINDOW COVERINGS

Commitment...

For over 100 years SWF has been synonymous with quality and innovation due to our commitment to excellence. This fundamental principle drives the company's research and development teams to develop distinctive products that are both functional and fashionable.

Conservation...

Graber® wood blinds are crafted exclusively from North American hardwoods, carefully harvested through the practice of "sustained yield forest management". Sound forestry techniques, as well as, the recycling of sawdust and wood shavings provides for a manufacturing process that puts the preservation of our natural resources first.

Control...

From green lumber to finished blinds, Graber® maintains complete control of wood quality. Hardwoods are kiln dried, molded and sanded to stringent specifications resulting in the highest quality, defect-free surface. Certified color technicians apply premium quality paints and stains in climate-controlled settings resulting in blinds with unmistakable beauty.

UNIQUE BENEFITS AND OPTIONS



SureClose® Headrail

Low-profile steel headrail with light blocking lip for tighter closure.

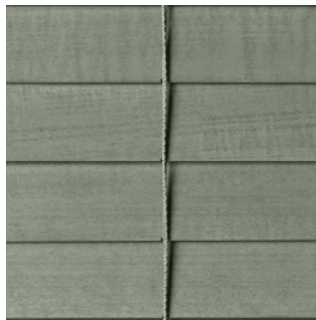

NoHoles™ Privacy Option

Eliminates route holes, providing superior privacy and light control.



Trapezoid Bottomrail

Provides superior closure. Available on Traditions 2" and Traditions Composite.

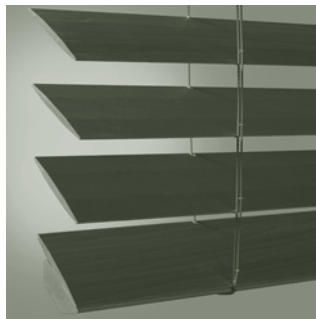

Shutter Style Slat Option

Distinctive 2-1/2" beveled hardwood slats with a profile reminiscent of true shutters.

GRABER® TRADITIONS™ WOOD BLINDS AND FAUX WOOD BLINDS

Product Features

GRABER® TRADITIONS™ WOOD BLINDS

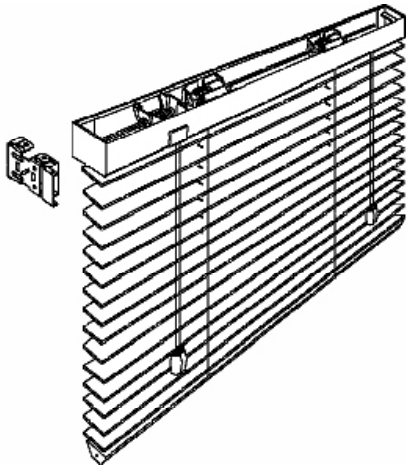

- **Slats exclusively North American hardwood harvested through the practice of "sustained yield forest management"**
- **SureClose® headrail system**
- **Trapezoid bottomrail**
- **PureGrain™ finish**
- **NoHoles™ option**
- **1" and 1-1/2" cloth tapes option**
- **Coordinating wood tassels**
- **1" and 2" slat options**
- **Lifetime headrail warranty**

Product Features

GRABER® TRADITIONS™ COMPOSITE WOOD BLINDS

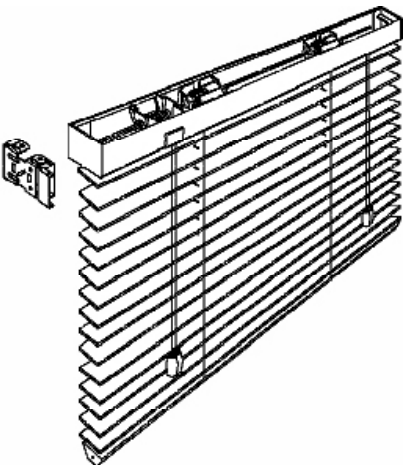

- **PVC polymer slats meet NFPA 701**
- **SureClose® headrail system**
- **Trapezoid bottomrail**
- **Authentic look of natural wood grain**
- **NoHoles™ option**
- **1" and 1-1/2" cloth tapes option**
- **Coordinating wood tassels**
- **Lifetime warranty**

Product Features

GRABER® LAKE FOREST™ FAUX WOOD BLINDS

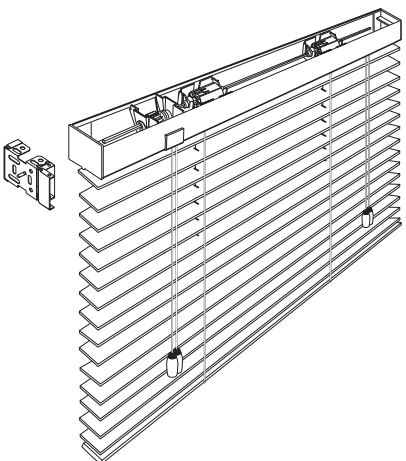

- **Flat 2" vinyl slats meet NFPA 701**
- **SureClose® headrail system**
- **Cord tilt**
- **Braided ladder**
- **NoHoles™ option**
- **2-1/2" wide slat option**
- **Five year warranty**

Characteristics...

As with fingerprints, no two trees are exactly alike. The characteristics of quality hardwoods are such that each piece of cut wood reveals the tree's growth story. Shown here are some examples of a tree's natural "character" you can expect to find in Graber Wood Blinds.

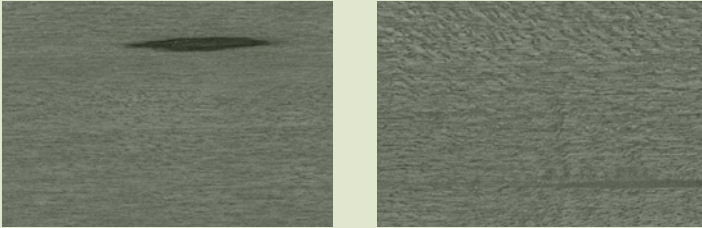

Mineral Marks

Dark or discolored area caused by minerals that the tree extracts from the water or soil; can appear as a streak or a stain. Mineral Marks have varying degrees of darkness from very light to nearly black. Also known as mineral deposits, sugar deposits or dark marks.

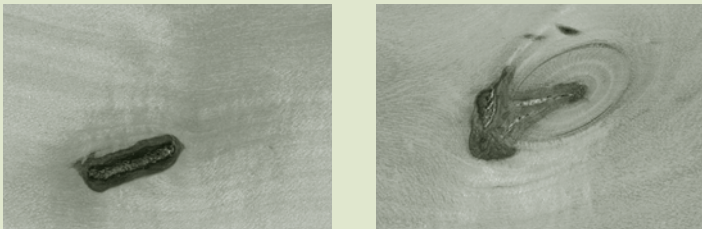
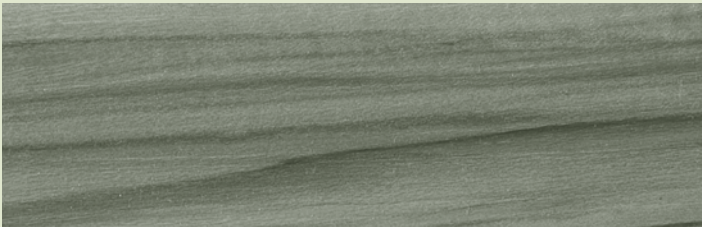

Knotty Pine

Knotty Pine material contains markings that are more extreme than in standard products.

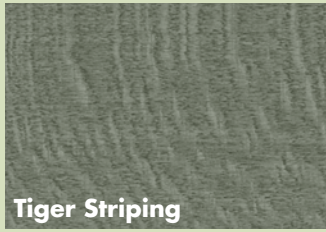

Tiger Striping



Flat Grain



Grain Change

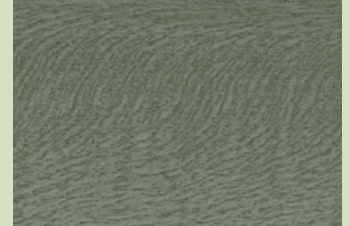

Grain

The direction, size and appearance of wood fibers vary greatly depending on where the wood is cut from within the tree. The type, direction and density of the grain is unique within each piece of wood, thus creating a truly individual pattern.

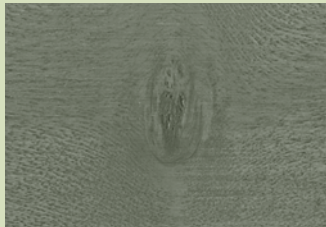

Pin Knots

Markings that indicate the location of branches. They vary in size, shape, and color.



Burl

Formed from an irregular growth on the outer edge of the tree. Also known as Birds Eye.